



Best-In-Class Quiet Blending Technology

The ultimate blender with unparalleled sound reduction, exceptional beverage blends, and improved speed of service.

Smart Product Design

- NEW Twist-and-lock sound enclosure is easier to remove and clean
- NEW Advance Blade offers reduced noise, improved performance, and longer container life*
- Larger centering pad allows for simple, one-step cleaning
- Advanced vibration dampening technology results in a more enjoyable atmosphere
- 6 program buttons with 34 optimised settings for easier, consistent blending
- Air management and powerful 3-peak output HP motor reduces noise, improves reliability, and minimises downtime

*Based on internal testing



50031 • 58674

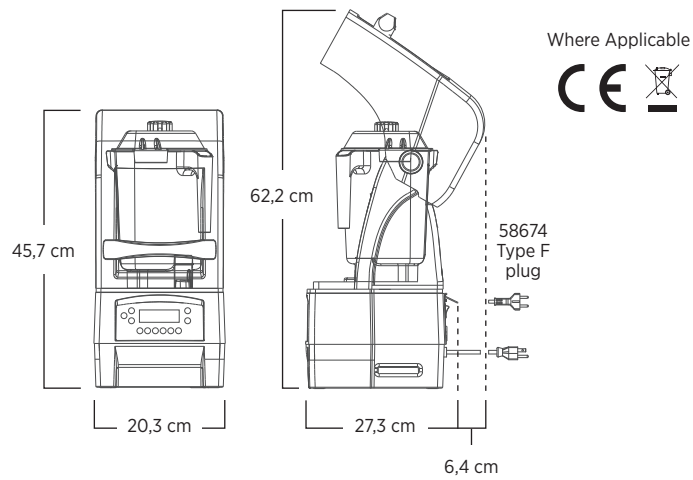

Includes The Quiet One with 1,4 L high-impact, clear/stackable Advance container complete with Advance blade assembly and lid, and removable compact enclosure.

For more complete warranty terms and conditions, please contact your authorised Vitamix distributor.

Product Specifications

Item Number	50031	58674 Type F Schuko plug
Motor	≈3 peak output horsepower motor	
Electrical	220-240 V, 50/60 Hz, 1300-1500 W	220 V, 50/60 Hz, 1300-1500 W
Net Weight	9,47 kg, (12,95 kg with box)	
Dimensions	45,7 x 20,3 x 27,3 cm (HxWxD) Height with lid open: 62,2 cm	

Also Available

58669	1,4 L clear BPA-Free, Advance container complete with Advance blade assembly and lid	
-------	--	--

Contact Information

+1.440.782.2450

international@vitamix.com



vitamix.com

For more information, please contact an authorised Vitamix distributor, or Vitamix international customer service.